



Equipment for
automatic NDT of
semi-ready materials



About NORDINKRAFT

NORDINKRAFT, headquartered in Remchingen, Germany, is a distinguished privately-owned company with a global presence.

For nearly two decades, NORDINKRAFT has been a leading provider of cutting-edge NDT (Non-Destructive Testing) solutions worldwide. Specializing in automatic examination of plates, coils, pipes, bars, and rails, we offer advanced technologies including EMAT, Arrays, Phased Arrays, and PEC for inspecting semi-ready products made of steel, titanium, or aluminum.

At NORDINKRAFT, our dedicated team of seasoned professionals, comprising scientists, engineers, and technicians, works diligently to uphold the highest standards of quality in every product we manufacture. We continuously push the boundaries of innovation, consistently enhancing our products and technologies to align with evolving industry trends and demands.

Building enduring partnerships with our clients is a cornerstone of our philosophy. We prioritize understanding our customers' unique needs, delivering tailored NDT solutions that surpass expectations, and providing reliable service to ensure their satisfaction.

NORDINKRAFT's vision is rooted in a commitment to success through innovation. We aspire to redefine industry standards by introducing groundbreaking solutions that set new benchmarks for excellence. Adhering to the strictest quality standards, our Quality Management System is certified under DIN ISO 9001:2015. This certification encompasses the manufacture, sales, and service of equipment, spare parts, and components related to all aspects of non-destructive testing.

At NORDINKRAFT, we are dedicated to driving progress, fostering innovation, and exceeding expectations every step of the way.



NORDISCAN-PL – In-line – Equipment for automatic ultrasonic in-line examination of plates with **TR phased array UT-probes**



Specifications of plates/coil to be tested

- Length 3 – 100 m and more
- Width 500 – 6000 mm
- Thickness 3 – 250 mm
- Material – carbon steel etc.
- Temperature from +0 °C to +80 °C
- Test speed of up to 1,5 m/s

Main features

- Phased array based
- Perfect signal-to-noise ratio
- High and smooth sensitivity
- Wide range of thicknesses
- Small untested zones
- Test capacity – up to 80 plates/hour (for 12 m long plates)
- Meets most of international norms and specifications

NORDISCAN-PL – Off-line – Equipment for automatic ultrasonic off-line examination of plates with **TR phased array UT-probes**



Specifications of plates to be tested

- Length 1 – 50 m
- Width 500 – 6000 mm
- Thickness 3 – 250 mm
- Material – carbon steel etc.
- Temperature from +0 °C to +80 °C
- Plates are on the floor or on the roller conveyor

Main features

- Phased array based
- Perfect signal-to-noise ratio
- High and smooth sensitivity
- Wide range of thicknesses
- Small untested zones
- Test capacity – up to 12 plates/hour (for 12 m long plates)
- Meets most of international norms and specifications

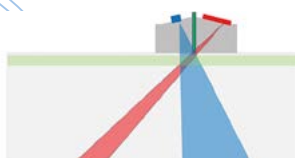

0-3 mm

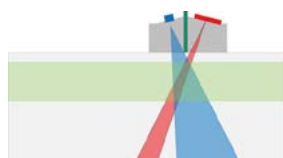

3-40 mm

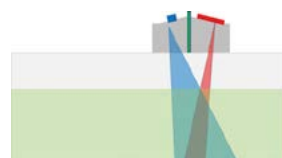

40-250 mm

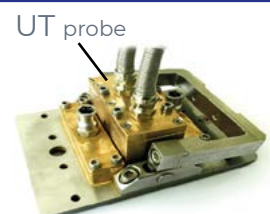

UT probe

EMATEST-PL – In-line – Equipment for automatic ultrasonic in-line examination of plates with **EMAT** (non-contact UT-probe)



Specifications of plates to be tested

- Length 3 – 100 m and more
- Width 500 – 6000 mm
- Thickness 3 – 60 mm
- Material – carbon steel etc.
- Temperature from -20 °C to +600 °C
- Test speed of up to 1,5 m/s

Main features

- EMAT based, non-contact
- High and smooth sensitivity
- Wide range of temperatures
- Small untested zones
- Test capacity – up to 80 plates/hour (for 12 m long plates)
- Meets most of requirements of international norms and specifications



EMATEST-PL – Off-line – Equipment for automatic ultrasonic off-line examination of plates with **EMAT** (non-contact UT-probe)



Specifications of plates to be tested

- Length 1 – 50 m
- Width 500 – 6000 mm
- Thickness 3 – 60 mm
- Material - carbon steel etc.
- Temperature from -20 °C to +600 °C
- Test speed of up to 1,5 m/s
- Plates are on the floor or on the roller conveyor

Main features

- EMAT based, non-contact
- High and smooth Sensitivity
- Wide range of temperatures
- Small untested zones
- Test capacity – up to 10 plates/hour (for 12 m long plates)
- Meets most of requirements of international norms and specifications



-50 °C



Up to +650 °C

EMATEST-Coil – Equipment for automatic ultrasonic in-line examination of coils with **EMAT** (non-contact UT-probe)



Specifications of coil to be tested

- Length 3 – 100 m and more
- Width 500 – 4000 mm
- Thickness 3 – 30 mm
- Material – carbon steel etc.
- Temperature from -20 °C to +600 °C
- Test speed of up to 2.0 m/s

Main features

- EMAT based, non-contact
- High and smooth sensitivity
- Wide range of temperatures
- Small untested zones
- Meets most of requirements of international norms and specifications



NORDISCAN-PL-HS – Off-line – Equipment for automatic off-line examination of plates for **HARD SPOTS**



Specifications of plates to be tested

- Length 1 – 50 m
- Width 500 – 6000 mm
- Thickness 3 – 60 mm
- Material – carbon steel etc.
- Temperature from -10 °C to +100 °C
- Test speed of up to 1,0 m/s
- Plates are on the floor or on the roller conveyor

Main features

- Type of probe – PEC (pulse eddy current probe)
- Perfect signal-to-noise ratio
- High and smooth sensitivity
- Minimal hard spot to be detected 10 mm x 10 mm or less
- No influence of rolling scale
- No influence of residual magnetization
- Demagnetization is not required
- No untested zone on longitudinal and transversal edges
- Meets most of national and international norms and specifications
- Test capacity – up to 12 plates/hour (for 12 m long plates)

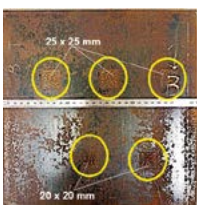

Severely magnetized fragment of steel plate

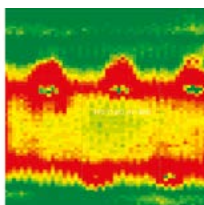

Scan obtained by means of "single frequency" mode

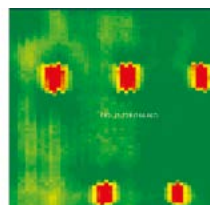

Scan obtained by means of "multi-frequency" mode

NORDISCAN-PL-HS – In-line – Equipment for automatic In-line examination of plates and coils for **HARD SPOTS**

Specifications of plates to be tested

- Length 1 – 100 m and more
- Width 500 – 6000 mm
- Thickness 3 – 60 mm
- Material – carbon steel etc.
- Temperature from -10 °C to +100 °C
- Test speed of up to 1,0 m/s
- Plates are on the roller conveyor

Main features

- Type of probe – PEC (pulse eddy current probe)
- Perfect signal-to-noise ratio
- High and smooth sensitivity
- Minimal hard spot to be detected 10mm x 10 mm or less
- No influence of rolling scale
- No influence of residual magnetization
- Demagnetization is not required
- No untested zone on longitudinal and transversal edges
- Meets most of national and international norms and specifications
- Test capacity – up to 80 plates/hour (for 12 m long plates)
- Test is performed from above. Additional unit with PEC-probes located under the plate is optional.



NORDISCAN-PL-HS + UT – Off-line – Equipment for automatic off-line examination of plates for **HARD SPOTS and Laminations**

Specifications of plates to be tested

- Length 1 – 50 m
- Width 500 – 6000 mm
- Thickness 3 – 250 mm
- Material – carbon steel etc.
- Temperature from -10 °C to +100 °C
- Test speed of up to 1,0 m/s
- Plates are on the floor or on the roller conveyor

Main features

- Type of probes – PEC-and-Phase Array UT-probes (Hybrid probes)
- Simultaneous test for hard spots and laminations
- Perfect signal-to-noise ratio
- High and smooth Sensitivity
- Minimal hard spot to be detected 10mm x 10 mm or less
- Small or no untested zones at edges
- No influence of rolling scale
- No influence of residual magnetization
- Demagnetization is not required
- No untested zone on longitudinal and transversal edges
- Meets most of national and international norms and specifications
- Test capacity – up to 12 plates/hour (for 12 m long plates)

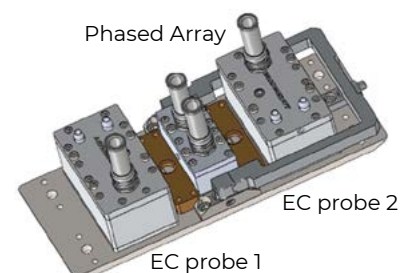

Our HYBRID solution!

NORDISCAN-PL (immersion) – Equipment for immersion automatic off-line UT of plates and slabs made of titanium or aluminum

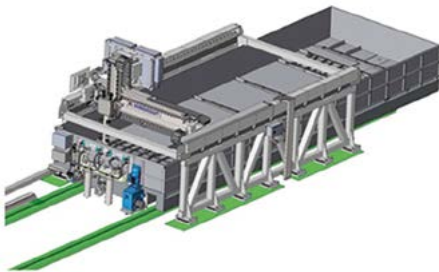

Specifications of plates to be tested

- Length – from 3 m to 12 m
- Width 100 mm – 3000 mm
- Thickness 3-200 mm
- Material – Titanium or aluminum

Main features

- Immersion test
- Perfect signal-to-noise ratio
- Types of probes – immersion phased array and conventional UT-probes
- Layer-to-layer electronical scanning by phase array focusing technique
- Sensitivity – FBH 0,8 mm and higher
- Untested zones – 1,5 mm under surfaces
- Automatic calibration and verification
- Standards – AMS, NADCAP, BOEING, AIRBUS, ASTM, EN, IGC
- Reference test capacity, about – 10 m²/hour for thickest plate

ALUTEST-PL (non-immersion) – Equipment for automatic off-line UT of aluminium plates and slabs

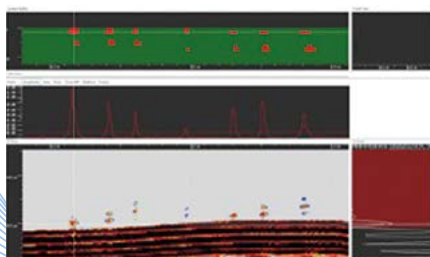

Specifications of plates/slabs to be tested

- Length from 1 m to 20 m
- Width 1 – 5 m
- Thickness 3-800 mm
- Material aluminum, titan etc.

Main features

- Type of probes – phased Array UT-probes
- Sensitivity for internal defects – FBH-0,8 mm
- Sensitivity for surface defects – notch 0,2 mm x 10 mm (D x W)
- Automatic calibration and verification
- Standards AMS, NADCAP, BOEING, AIRBUS, ASTM, EN, IGC
- Reference test capacity: time for testing of one plate of 8 m x 3 m is about 30 min for thickest plate

RIDER-NK-300 – push-cart for ultrasonic examination of plates with **TR PHASED ARRAY PROBES**



Specifications of plates to be tested

- Length 1 – 50 m
- Width 500 – 6000 mm
- Thickness 3 – 250 mm
- Material – carbon steel etc.
- Temperature from +0 °C to +60 °C
- Plates are on the floor

Main features

- Phased array based
- Perfect signal-to-noise ratio
- High and smooth sensitivity through the whole plate thickness
- Wide range of thicknesses
- Small untested zones
- Test capacity – up to 7 plates/hour (for 12 m x 4 m plates)
- Meets most of international norms and specifications

RIDER-NK-HS – push-cart for examination of plates for **HARD SPOTS with PEC**

Specifications of plates to be tested

- Length 1 – 50 m
- Width 500 – 6000 mm
- Thickness 3 – 250 mm
- Material - carbon steel etc.
- Temperature from +0 °C to +60 °C
- Plates are to be tested on the floor

Main features

- Type of probes – PEC-probes
- Perfect signal-to-noise ratio
- High and smooth sensitivity
- Minimal hard spot to be detected 10 mm x 10 mm or less
- Small or no untested zones at edges
- No influence of rolling scale
- No influence of residual magnetization
- Demagnetization is not required
- Meets most of national and international norms and specifications
- Test capacity – up to 7 plates/hour (for 12 m x 4 m plates)

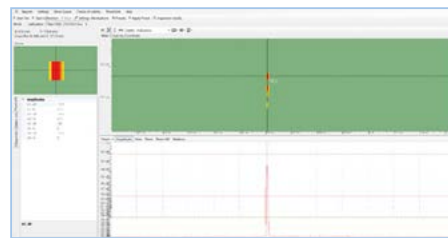

NORDISCAN-BB-200 – Equipment for local immersion automatic ultrasonic in-line examination of bars



Specifications of bars to be tested

- Length from 3000 mm to 14000 mm
- Diameter – 10 – 200 mm
- Material – steel, aluminum etc.
- Test speed up to 2 m/s depending on diameter

Main features

- Type of test – local immersion
- Type of UT probes – multi-channel arrays
- High signal-to-noise ratio
- No rotation of the probes is needed
- Sensitivity – up to FBH 0,7 mm
- Small untested zones
- Meets all modern specifications and standards including AMS, NADCAP, BOEING, AIRBUS, ASTM, EN, IGC



NORDISCAN-BB-200-Hybrid – Equipment for local immersion automatic ultrasonic in-line examination of bars and billets



Specifications of bars/billets to be tested

- Length from 3000 mm to 14000 mm
- Diameter/Side – 10 – 200 mm
- Material – Steel, aluminum etc.
- Test speed up to 2 m/s depending on diameter/ billet side dimension

Main features

- Both bars and billets can be tested
- Type of test – local immersion
- Type of UT probes – multi-channel arrays
- High signal-to-noise ratio
- No rotation of the probes is needed
- Sensitivity – up to FBH 0,7 mm
- Small untested zones
- Meets all modern specifications and standards including AMS, NADCAP, BOEING, AIRBUS, ASTM, EN, IGC



Our HYBRID solution!

ALUTEST-BB-200 – Equipment for immersion automatic ultrasonic in-line examination of bars



Specifications of bars to be tested

- Length from 3000 mm to 14000 mm
- Diameter/Side – 10 – 200 mm
- Material – aluminum, steel etc.
- Test speed up to 2 m/s depending on diameter/ billet side dimension

Main features

- Type of test – immersion
- Type of UT probes – multi-channel arrays
- Highest level of signal-to-noise ratio
- No rotation of the probes is needed
- Sensitivity – up to FBH 0,4 mm
- Small untested zones
- Meets all modern specifications and standards including AMS, NADCAP, BOEING, AIRBUS, ASTM, EN, IGC



NORDISCAN-BB-F – Equipment for local immersion automatic ultrasonic off-line examination of flat bars

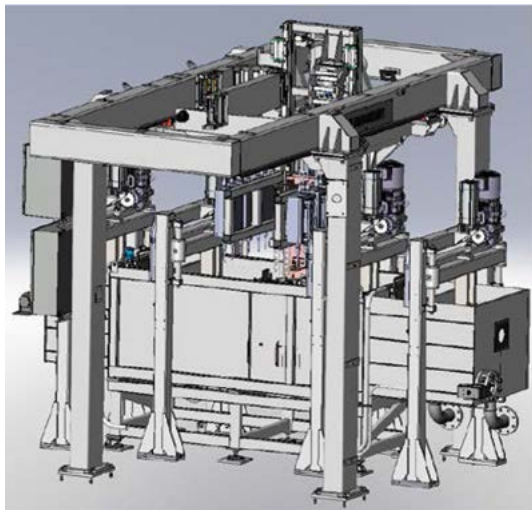

Specifications of flat bars to be tested

- Length from 3000 mm to 12000 mm
- Sections range: from 15x15mm to 90x110mm
- Material stainless steel
- Test speed up to 1 m/s

Main features

- Both bars and billets can be tested
- Type of test – local immersion tank
- Defects to be detected – internal defects and surface and transversal cracks
- Type of UT probes – multi-channel arrays
- High signal-to-noise ratio
- No rotation of the probes is needed
- Sensitivity:
 - up to FBH 0,7 mm
 - transversal and longitudinal notches 0,2 mm x 10 mm
- Small untested zones
- Meets all modern specifications and standards including AMS, NADCAP, BOEING, AIRBUS, ASTM, EN, IGC



NORDISCAN-BB-500 – Systems for automatic ultrasonic off-line examination of **steel/aluminium bars**



Specifications of bars/billets to be tested

- Length from 3000 mm to 14000 mm
- Diameter – 100 – 500 mm
- Material – steel, aluminum etc.

Main features

- Type of test – local immersion
- Type of UT probes – multi-channel arrays
- High signal-to-noise ratio
- Rotation of bars is needed
- Sensitivity – up to FBH 0,7 mm
- Small untested zones
- Meets all modern specifications and standards

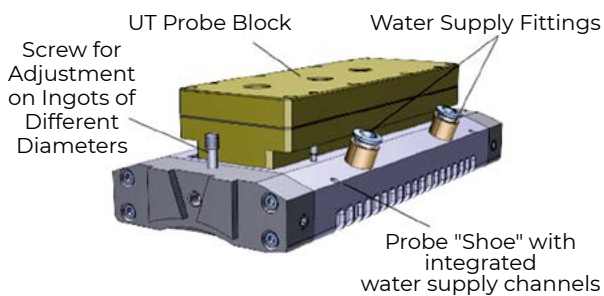

Rails

NORDISCAN-RAIL-I – Equipment for automatic ultrasonic in-line examination of rails for **INTERNAL DEFECTS**



Specifications of rails to be tested

- Length up to 150 m and more
- Rails types P50, P65, P75, OP50, OP65, 60E1A1, 54E1A1, 54E1A2, 49E1A2, 49E1, 49E2, 50E6, 60E1, 60E2 etc.
- Test speed - up to 2 m/s

Main features

- Test in local immersion tank
- Type of detected defects – internal defects through the whole perimeter
- High signal-no-noise ratio
- Type of probe - Phased Array
- Electronical adjustment for new types of rails takes less than 20 min
- Sensitivity for Internal Defects: Meets most of specification and standards, e.g. AREMA, EN, GOST, local standards

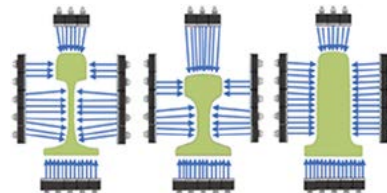
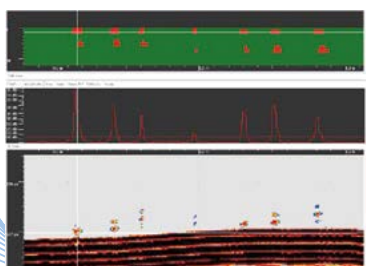

NORDISCAN-RAIL-S – Equipment for automatic ultrasonic in-line examination of rails for **SURFACE DEFECTS**



Specifications of rails to be tested

- Length up to 150 m and more
- Rails types P50, P65, P75, OP50, OP65, 60E1A1, 54E1A1, 54E1A2, 49E1A2, 49E1, 49E2, 50E6, 60E1, 60E2 etc.
- Test speed - up to 2 m/s

Main features

- Test in local immersion tank
- Type of detected defects – longitudinal, transversal, and complicated shapes of surface defects around the whole perimeter
- High signal-to-noise ratio
- Type of probe - Phased Array
- Electronic adjustment for new types of rails takes less than 20 min
- Sensitivity for surface defects:
 - 0,2 x 20 x 0,5 mm for longitudinal
 - 0,2 x 10 x 0,5 mm for transversal
- Meets most of specification and standards, including AREMA, EN, GOST, local standards

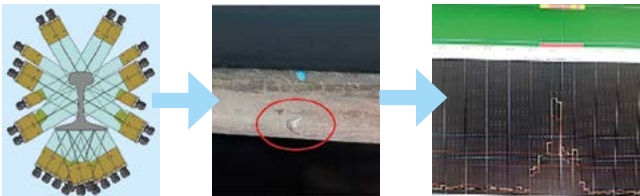

EMATEST-RAIL – Equipment for non-contact automatic ultrasonic in-line examination of rails for **INTERNAL DEFECTS with EMAT**

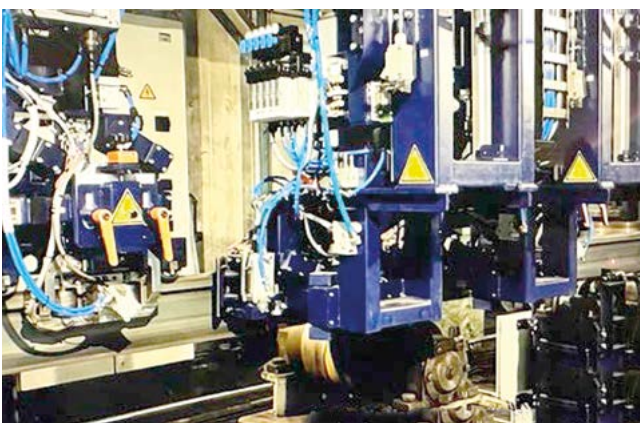

Specifications of rails to be tested

- Length up to 150 000 mm
- Rail types P50, P65, P75, OP50, OP65, 60E1A1, 54E1A1, - 54E1A2, 49E1A2, 49E1, 49E2, 50E6, 60E1, 60E2
- Material carbon steel
- Test speed up to 2 m/s

Main features

- Type of probe EMAT (non-contact)
- Sensitivity for internal defects: according to GOST

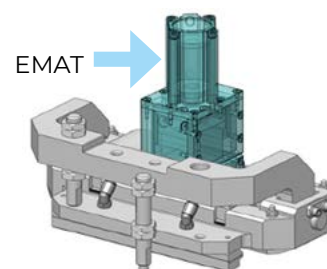

NORDISCAN-W – Equipment for immersion automatic ultrasonic in-line examination of railway wheels

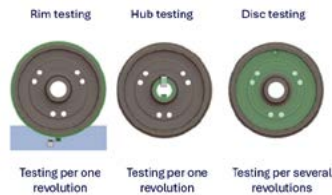
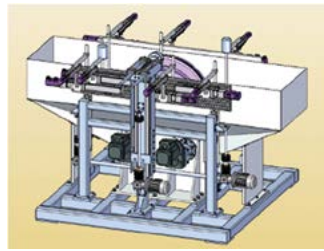

Specifications of railway wheels to be tested

- All standard sizes of solid-rolled railway wheels in accordance with BN 277 918, AAR M-107 / M-208, EN 13262:2004, GOST 10791-2011 and other international standards
- Test capacity 80 s for one wheel – rim, hub, disk

Main features

- Sensitivity – up to FBH \varnothing 1.0 mm for rim
- Type of test – immersion
- A, B, C scans available
- Type of UT probes - multi-channel phase arrays
- Highest level of signal-to-noise ratio
- Small untested zones
- Meets all modern specifications and standards

Pipes and Tubes

NORDISCAN-PI-LSAW – Equipment for automatic ultrasonic in-line examination of LSAW pipes



Carriage solution



Gantry solution

Specifications of pipes to be tested

- Diameter 406 mm – 1524 mm
- Wall thickness 6 mm – 60 mm
- Material carbon steel, all grades of API 5L
- Test capacity – up to 15 pipes per Hour

Main features

- Type of probes - conventional and Phased Array probes
- Meets all the internationally recognized norms and specifications including DEP 31.40.20.37 – February 2023 (adopted IOGP), International Association of Oil & Gas Producers (IOGP) IOGP S-616 Ver.1.0 (2019), Ver.2.0 (2022) “Supplementary Specification to API Specification 5L and ISO 3183 Line Pipe” DNV-ST-F101- 2021 ASTM-E-317:2021 GS EP PLR 202 Rev.8 “Fabrication of longitudinally submerged arc welded pipes for pipelines (sweet service)”

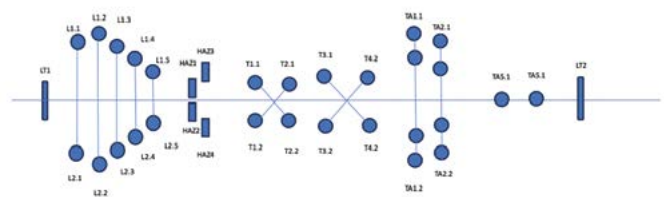

NORDISCAN-PI-ERW – Equipment for automatic ultrasonic in-line examination of **ERW pipes (Body + Ends)**



Specifications of pipes to be tested

- Diameter 80 mm – 570 mm
- Wall thickness 4 mm – 30 mm
- Material carbon steel, all grades of API5L

Main features

- Type of probe – Multi-channel array probes
- Coverage – all body including ends
- Sensitivity according to API 5L and other
- Standards and specifications for ERW pipes
- Test capacity – up to 160 pipes per hour



NORDISCAN-PI-W – Equipment for automatic ultrasonic in-line examination of **ERW pipes (weld + HAZ inspection)**



Specifications of pipes to be tested

- Diameter 80 mm – 570 mm
- Wall thickness 4 mm – 30 mm
- Material carbon steel, all grades of API 5L

Main features

- Type of probe single crystal angle probes or phase array UT-probes
- Sensitivity SDH 1.6 mm, up to N5
- Automatic tracking of weld seam
- Fully automatic calibration
- Meets all international specifications

NORDISCAN-PI-S – Equipment for automatic ultrasonic in-line examination of **SEAMLESS and ERW pipes**

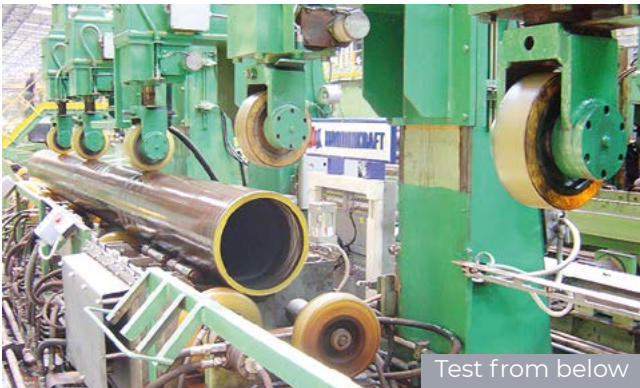

Specifications of pipes to be tested

- Diameter 32 mm – 426 mm
- Wall thickness 3 mm – 40 mm
- Material carbon steel, API grades

Main features

- Type of probe – multi-channel UT array probes
- Pipes move and rotate
- Sensitivity according to API Spec 5 DP and other standards for seamless pipes
- Test capacity – up to 200 pipes per Hour

EMATEST-PI-WT – Equipment for automatic ultrasonic in-line non-contact wall thickness measurement



Specifications of pipes to be tested

- Diameter 70 mm – 500 mm
- Wall thickness 0,5 mm – 50 mm
- Material – most of metals, including cast pipes

Main features

- Type of probe EMAT (non-contact)
- Wall thickness accuracy, up to $10\mu + 2R$



Our SONAFLEX is a flexible platform that can be modified for different ultrasonic testing tasks in field and laboratory conditions. SONAFLEX has 16 channels and can be equipped either with EMAT or Phased Array or Conventional Piezoelectric Probes. The SONAFLEX family includes:

- **SONAFLEX- MINI** is a wireless, powerful, compact, portable device designed for wall thickness measurement in laboratory and field conditions. It is equipped with a non-contact EMAT transducer.



- **SONAFLEX- GRAIN SIZE** is a compact and sophisticated gauge for automatic, non-contact in-line monitoring of grain size in dynamic steel grades, where grain size is a critical factor.

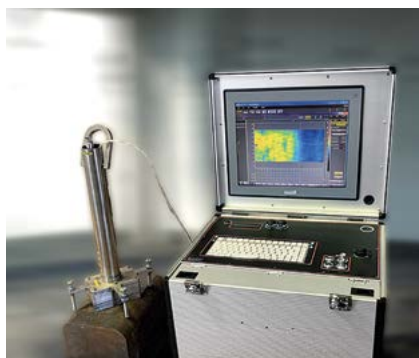
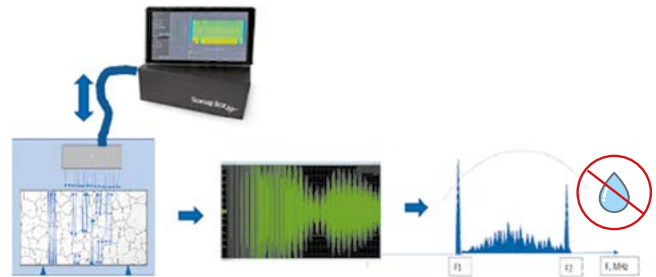

- **SONAFLEX-Liquid Core** is built to find the location of the liquid core in a cast bloom. The EMAT probes allow one to operate at the temperatures close to 1200 °C.

- **SONAFLEX-WTM** is designed to measure wall thickness of cylinders of combustion engines, even with different metal alloys during their serial production.

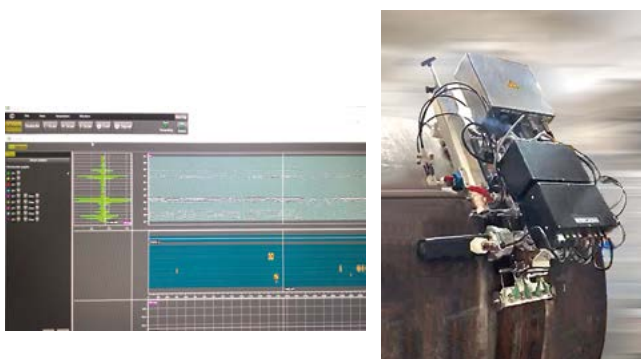

- **SONAFLEX-Weld** is a robot that is meant to inspect circumferential welds on pipelines. It has everything onboard including Phased Arrays and ATOFD probes.

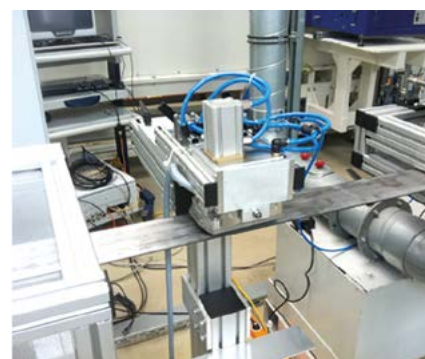

- **SONAFLEX-BiM** equipped with non-contact EMAT-probes is designed to measure lack of bond in bimetal materials.

CONTACTS

Nordinkraft AG
Schauinslandstr. 16
D 75196 Remchingen,
Germany

Tel: +49 (0) 7232 – 31335-0
Fax: +49 (0) 7232 – 31335-199

info@nordinkraft.de

<http://www.nordinkraft.de>



YOUR LOCAL
REPRESENTATIVE

